

SOLARSHEAT

**The SolarSheat
1500G/1500GS/1501GS –
Flush Roof Mount
Installation Manual**

**By
Your Solar Home, Inc.**

Version 1.0
December 28, 2006

*All building, plumbing, electrical, and safety codes supersede the instructions in this manual.
The manufacturer assumes no liability for improper installation. Use this manual at your own risk.*

This installation manual describes the flush roof mount installation of the 1500G, 1500GS, and 1501GS.

How it works: The SolarSheat 1500G panel heats inside air. The amount of heat produced is based on the volume of air passing through the solar panels and the degree of sunshine. The inline fan kit can be powered by an AC/DC wall adaptor or with an additional PV cell, to keep it off the grid.

Roof Mounting - SolarSheat 1500G

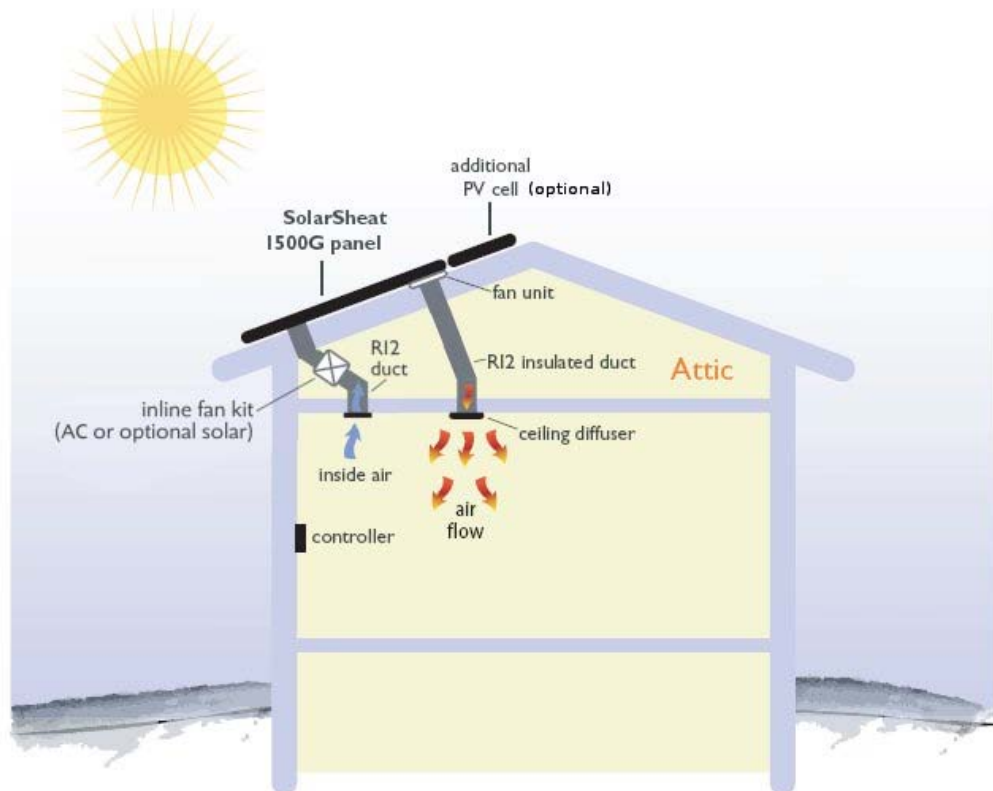

Equipment for proper installation:

- jig saw – bi-metal blade if necessary, for ducts' holes
- Drill
- 3/8" metal drill bit for tall unistrut pads
- 3/16" drill bit for pilot holes for 3/8" lag bolts
- prying tool for shingles
- Socket (square) driver bit for wall grill screws (if applicable)
- 9/16" hex socket driver for 3/8" lag bolts
- Utility knife for cutting template and shingles
- Small flat head screw driver for thermostat's wire terminals
- Metal strapping for securing duct to roof rafters
- Wood screws for screwing metal strapping to roof rafter
- Self drilling #8, or #10 x 3/4" for screwing collars to SolarSheat and metal strapping to duct
- Tape for taping the template on the roof
- Outdoor sealant – high quality outdoor silicon and outdoor polyurethane sealant
- Caulk gun
- Measuring Tape
- Level
- Clean rags – temporarily needed to plug up duct only to stop drywall/wood dust from entering collector if house is under construction, turn off thermostat. Remove rags from duct & turn on thermostat when construction is complete & construction dust has been cleaned up.
- Ducting (type, size, & length depends on individual situation)

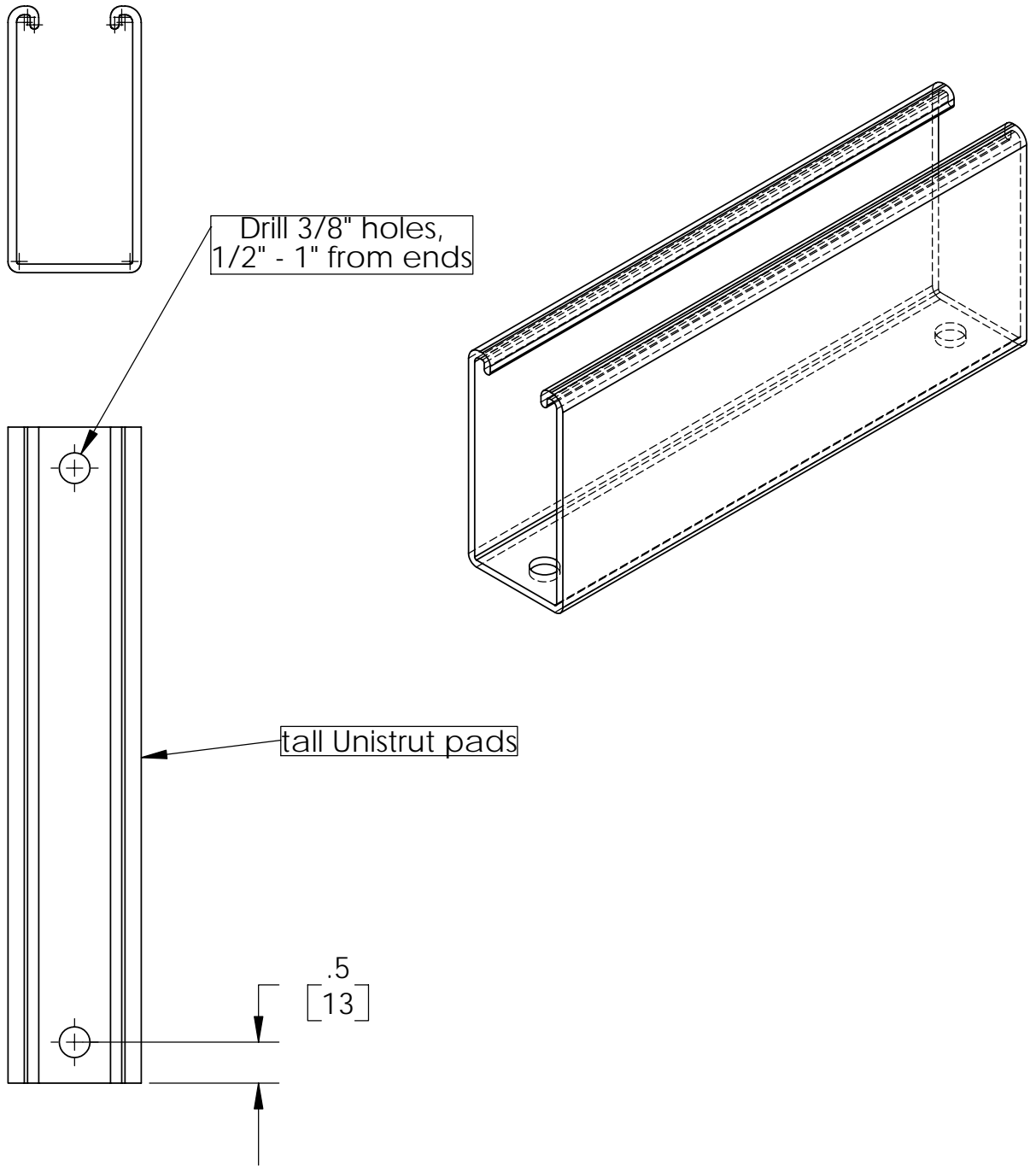

- Drill all tall Unistrut pads

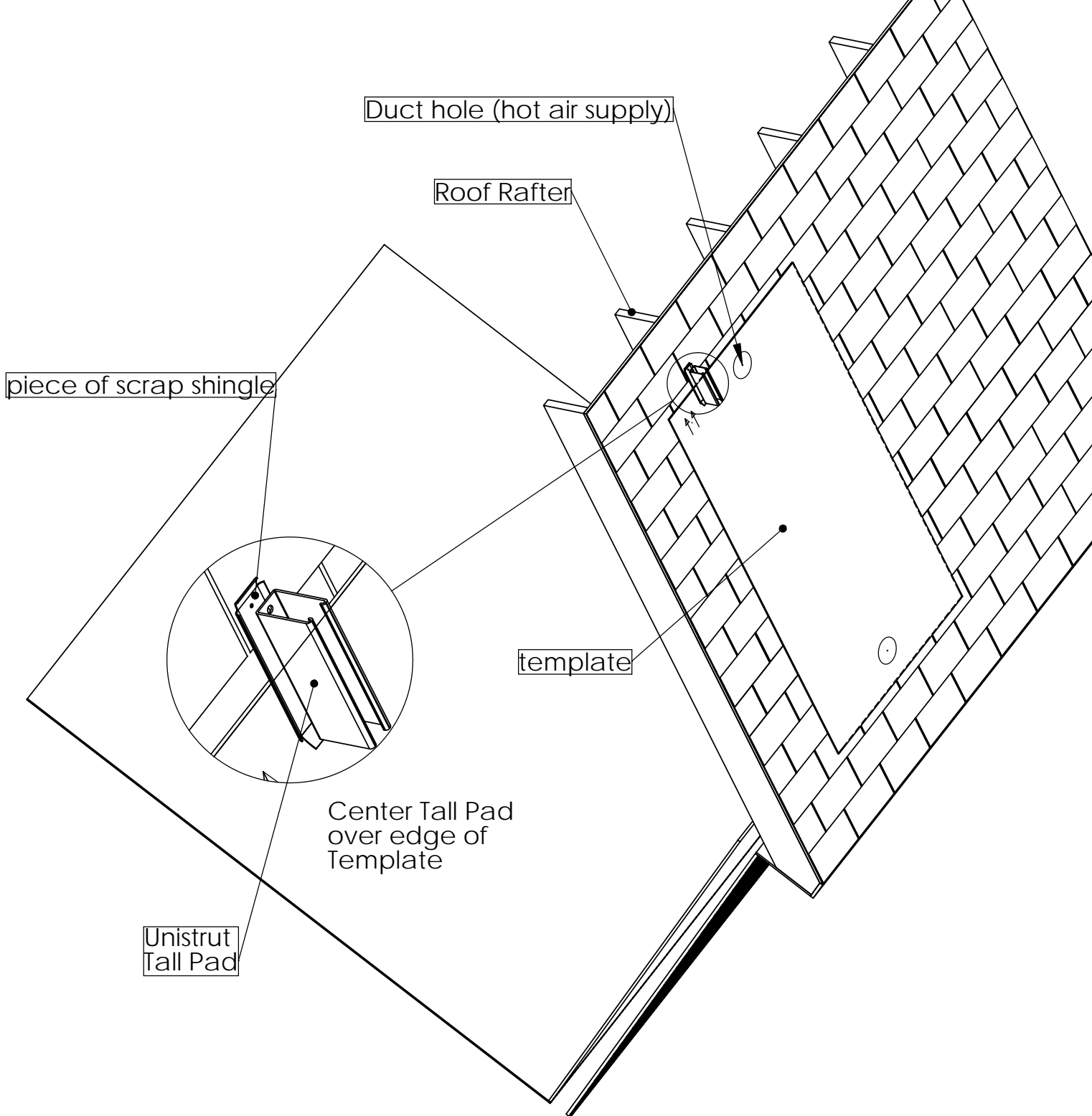

- Collector can be installed "landscape" style as well as "portait", as shown
- Find roof rafters
- Locate SolarSheat duct holes shown on template between roof rafters
- A SolarSheat 1500G should be mounted with PV section on top
- A SolarSheat 1500GS or 1501GS does not have a PV section, nor do they have a top or bottom, and can be mounted in any direction
- Be careful of electrical wires or other obstructions
- Tape template temporarily to roof
- Place a Unistrut tall pad over the edge of template
- Slip a piece of scrap shingle under the Unistrut tall pad - this can help reduce wear on the shingle(s) below the Unistrut tall pad.

- Drill pilot holes through the 2 holes made in the Unistrut, the roof, and the middle of the roof rafters
- Inject plenty of outdoor grade polyurethane into the pilot holes
- Screw in 3/8" x 3" lag bolts to hold the pads location over the pilot holes
- Place next unistrut pad over the appropriate rafter, centering it over the edge of the template.
- Repeat the above steps for remaining pads
- For 5" duct, cut a 5-1/2" - 6" hole through template and shingles with a utility knife.
- Cut duct holes through roof decking with a jig saw
- Remove template
- Tighten all lag bolts down.
- Surround and cover the head of the lag bolts with plenty of outdoor, high grade silicone or polyurethane

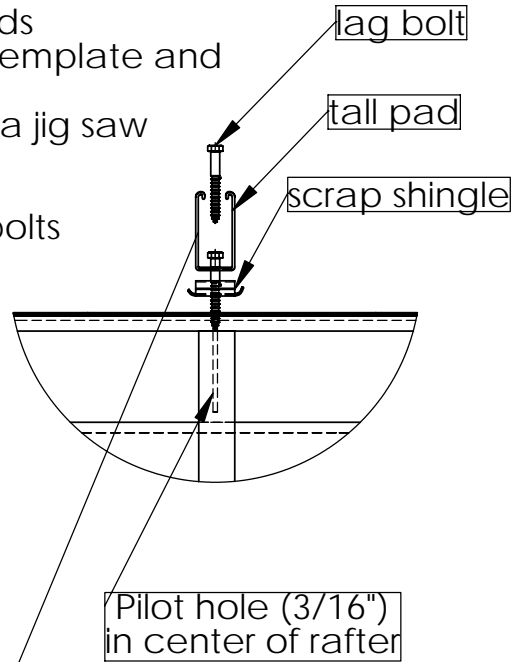

Return air duct hole

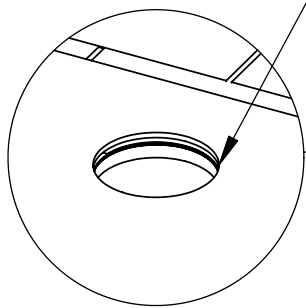

Supply air duct hole

- lift shingles above each duct hole enough to slip flashing under.
- double check flashings' location by placing template's holes over flashing, before nailing.
- nail flashing down
- cover nails with outdoor grade polyurethane/roofing sealant
- lay shingles back over flashing

Keep longer portion of flashing pointing up the slope

Trim flashing with scissors above the ridge marked for the duct size (5")

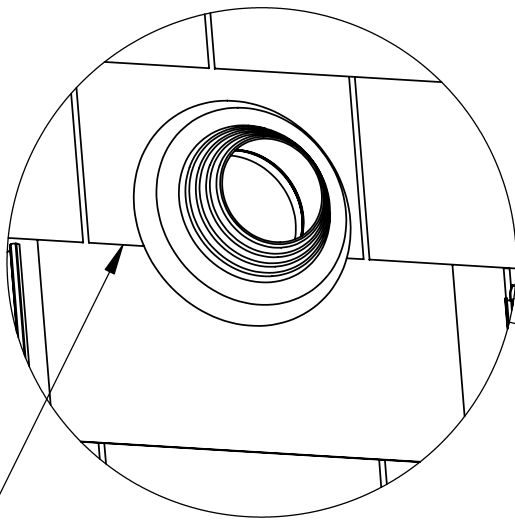
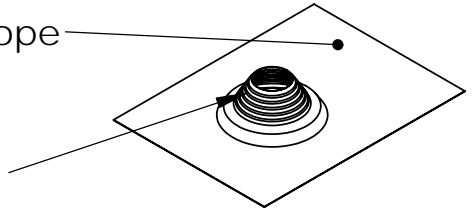

Shingles should extend at least to middle of rubber cone

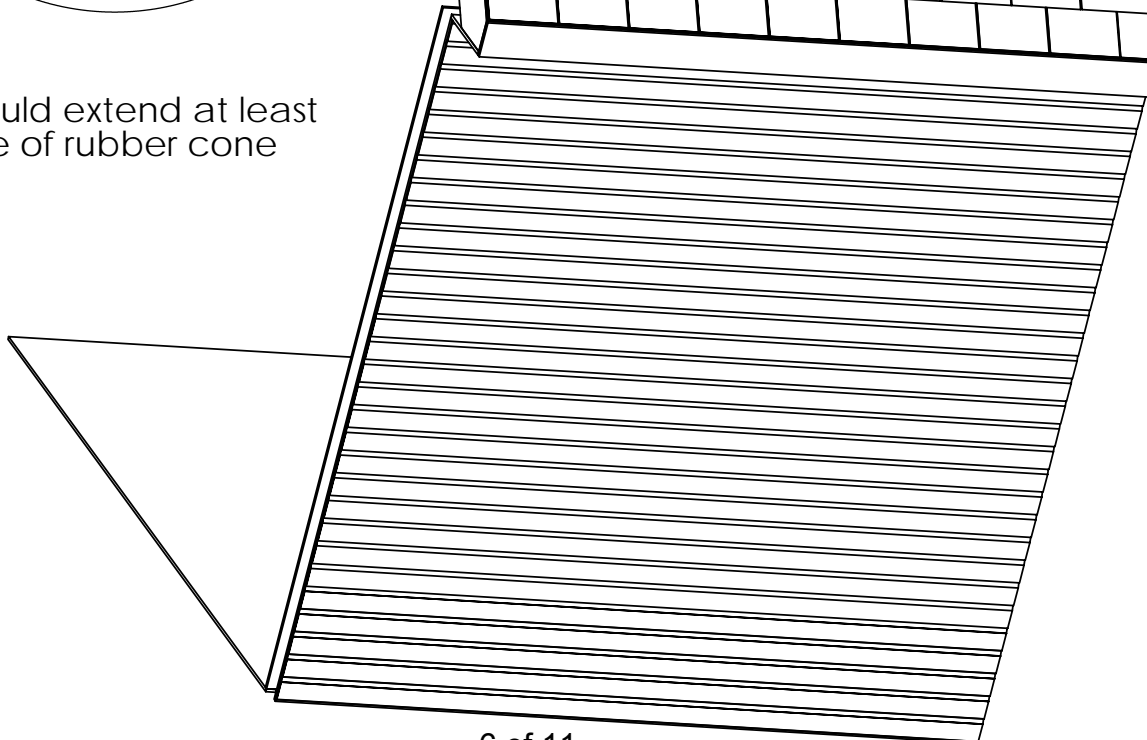
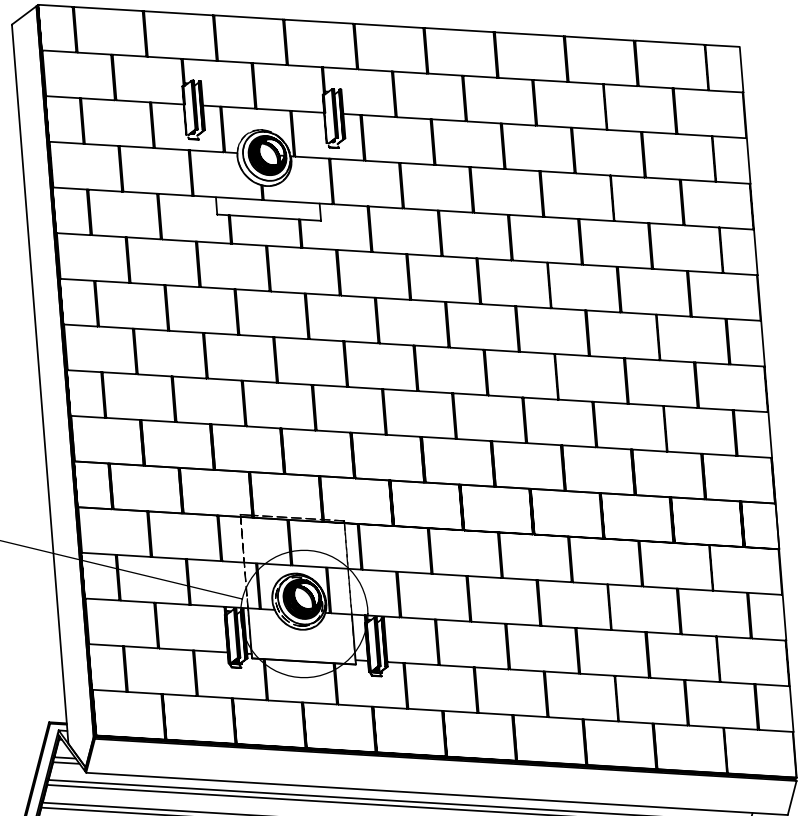

- Cut holes in SolarSheat backing insulation using a knife
- Install Duct Kit as shown below (for cathedral ceilings, if the distance between the interior drywall surface-to- exterior roof surface is greater than ~7", longer lengths of duct will be needed)
- For a SolarSheat 1500G, run thermostat wire through nearest passive roof attic vent, cut hole in screen (if applicable), and fasten to roof rafter inside. Alternatively install a "goose neck" flashing and run thermostat wire through it, sealing with spray foam.

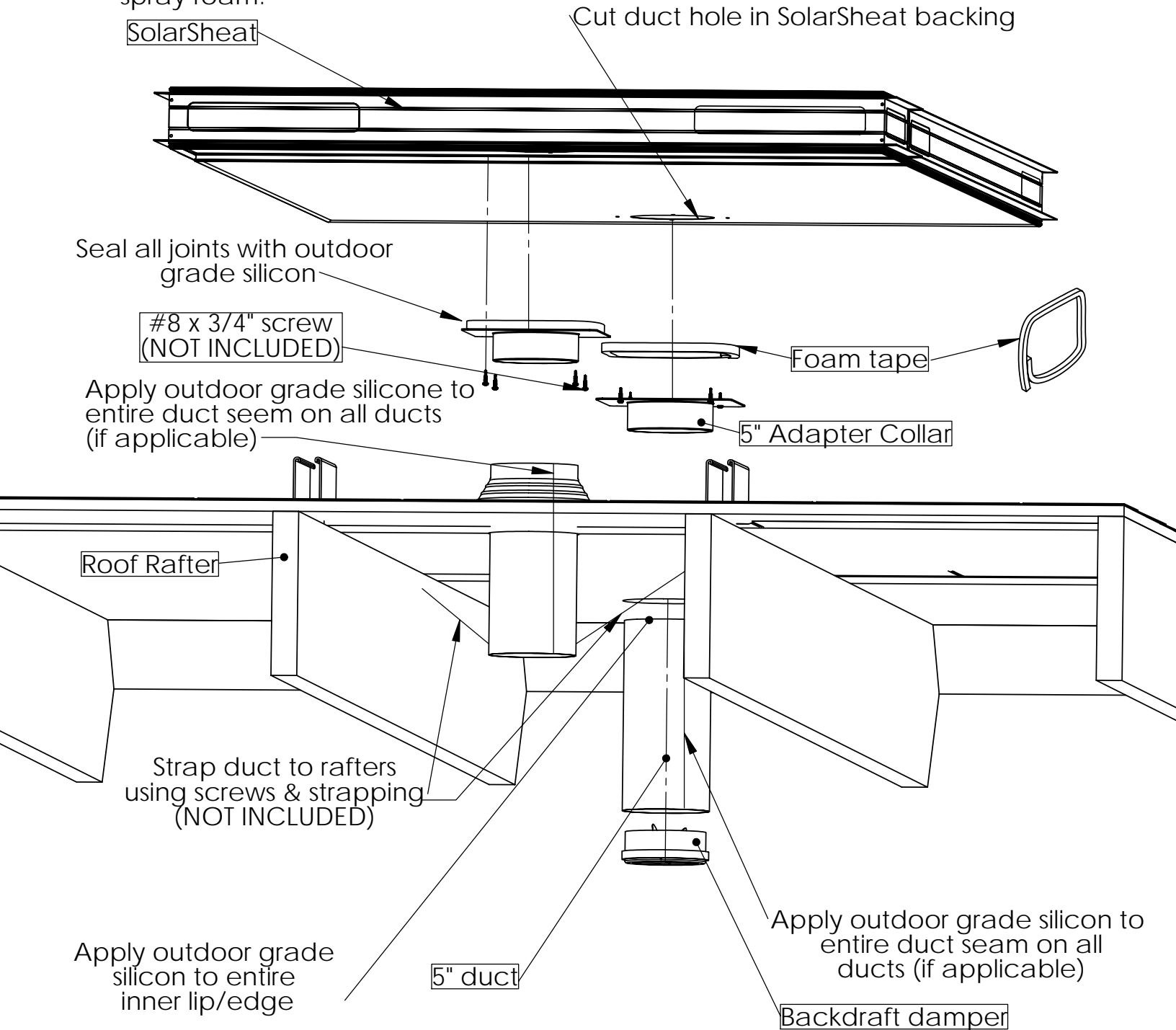

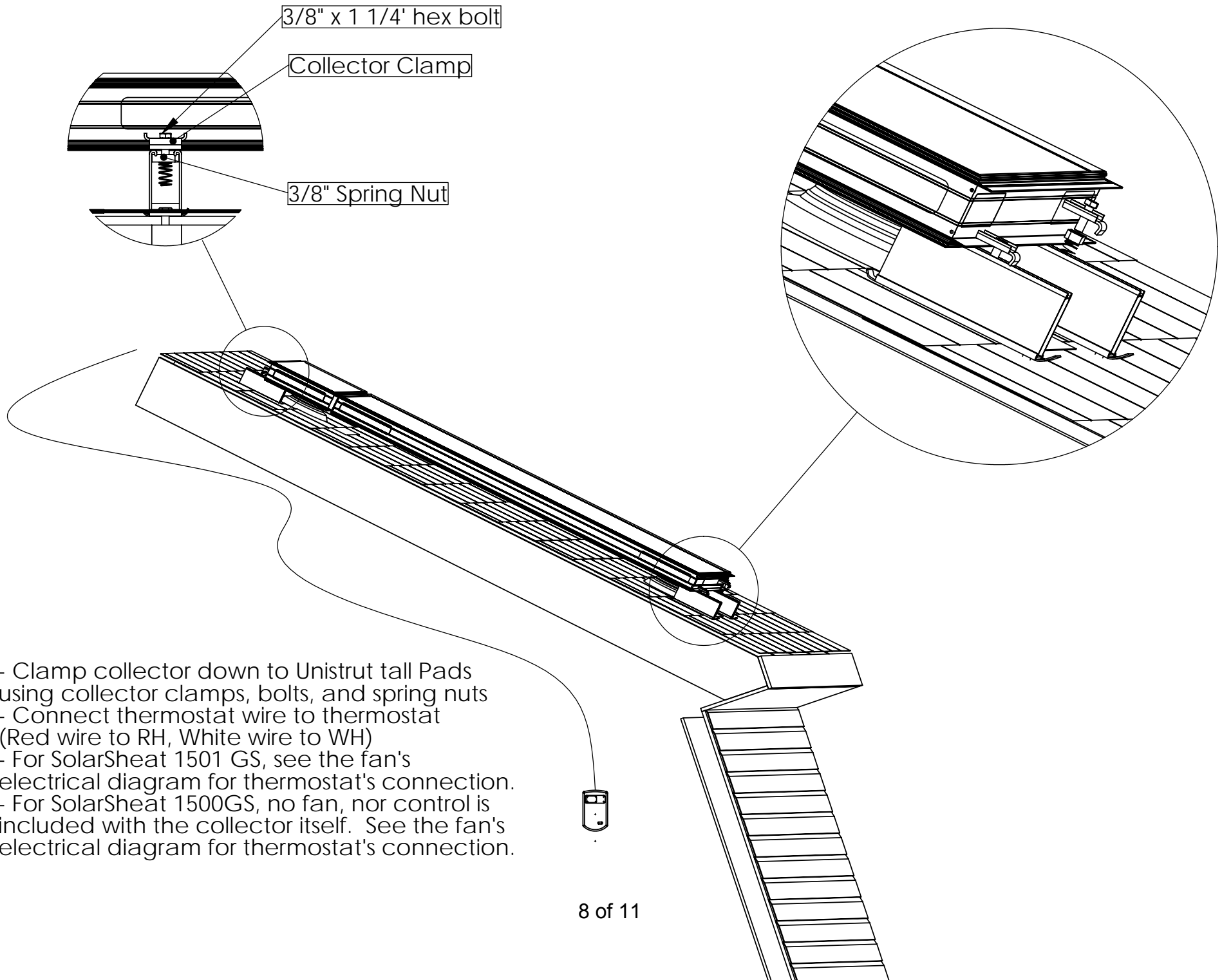

- Clamp collector down to Unistrut tall Pads using collector clamps, bolts, and spring nuts
- Connect thermostat wire to thermostat (Red wire to RH, White wire to WH)
- For SolarSheat 1501 GS, see the fan's electrical diagram for thermostat's connection.
- For SolarSheat 1500GS, no fan, nor control is included with the collector itself. See the fan's electrical diagram for thermostat's connection.

For Cathedral Ceilings:

- Install grills/diffusors

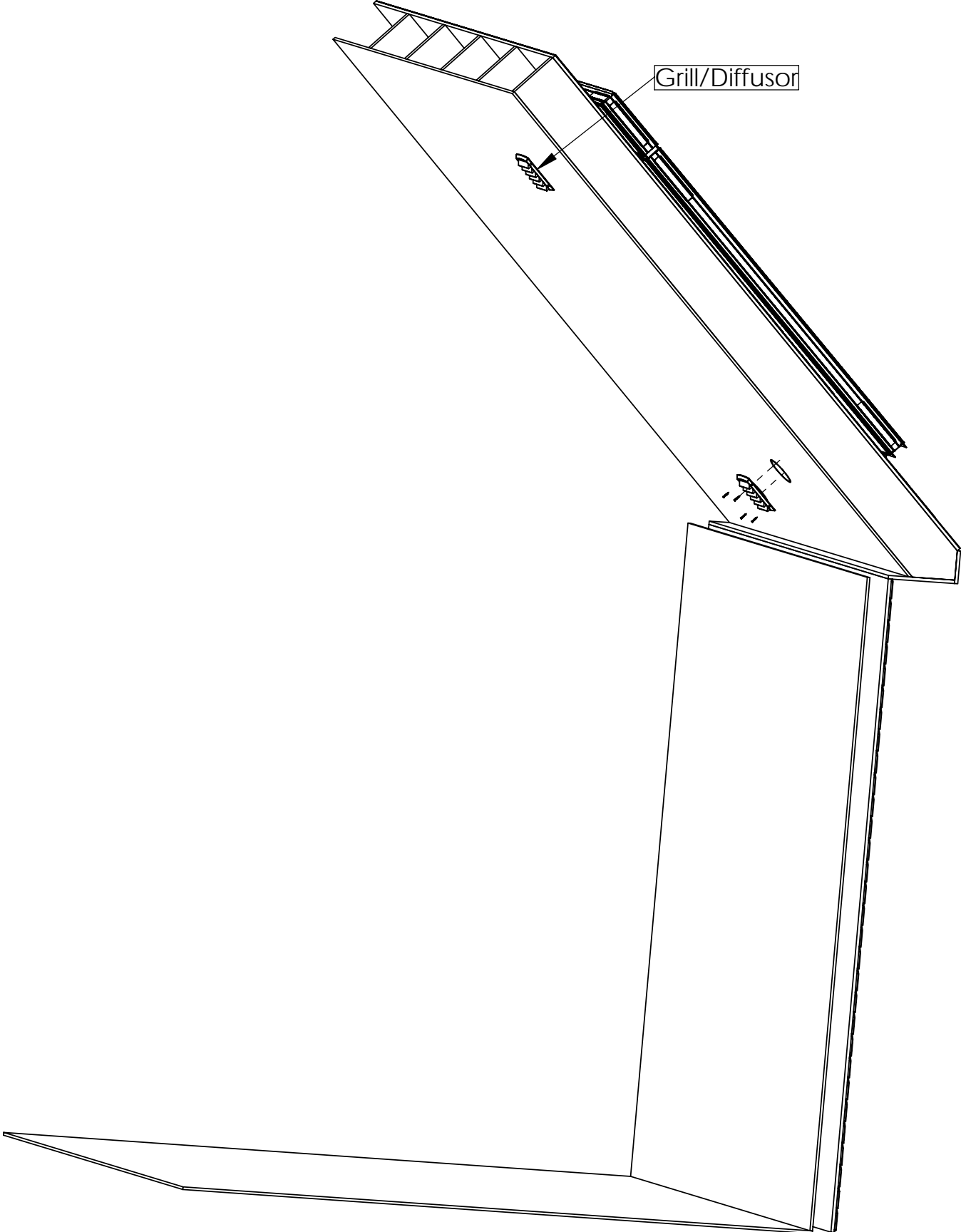

For Attics:

- For the SolarSheat 1500G, an Inline fan is needed when total duct length is more than ~6'.
- All fans should be located next to Solarheat intake duct. This way it will "push" air through Solarheat(s) - so as to help lengthen fan life
- see electrical diagram(s) for the fan's electrical connection
- Run R-12 Insulated duct between SolarSheat, fan (if applicable), and ceiling diffusers

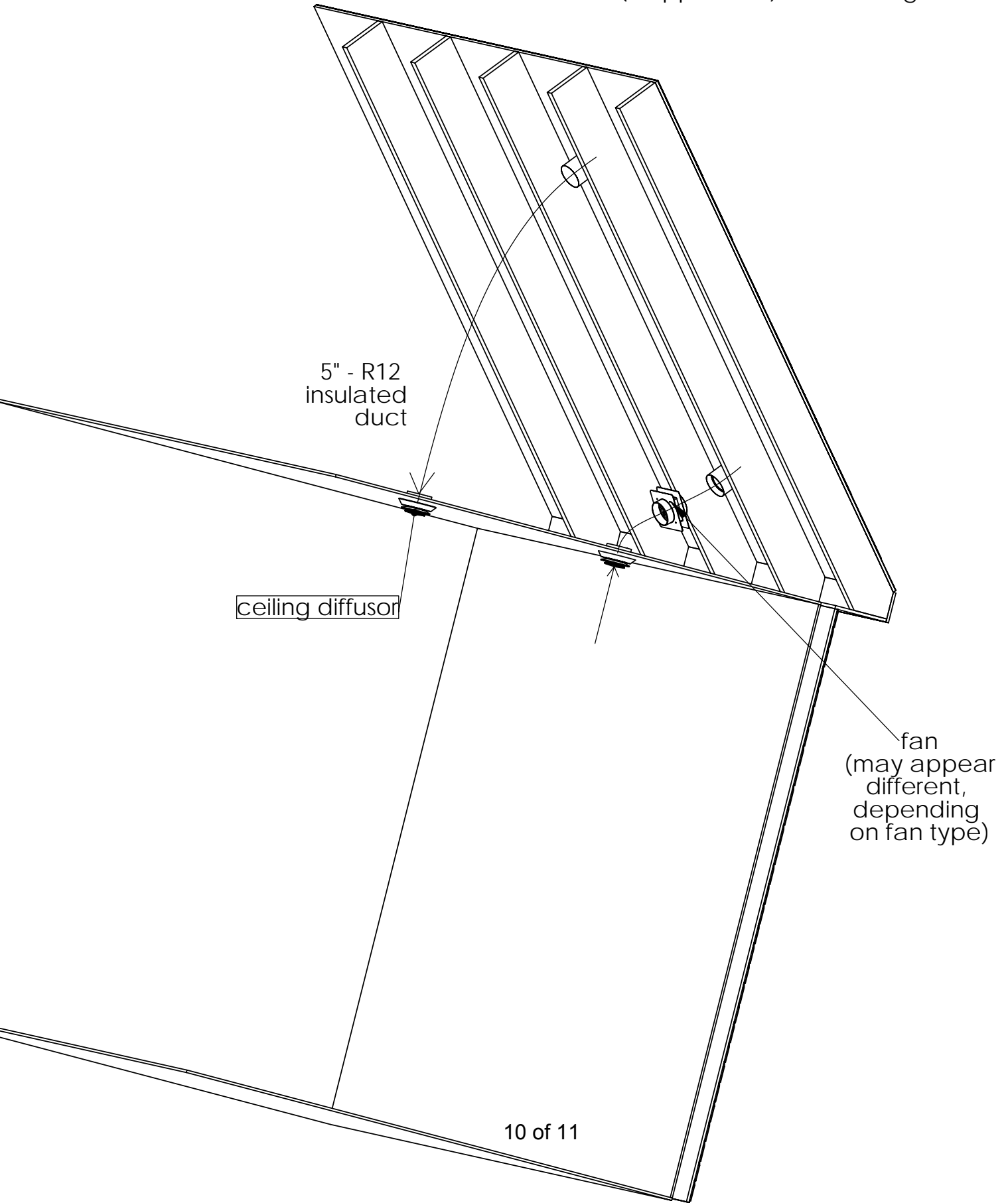

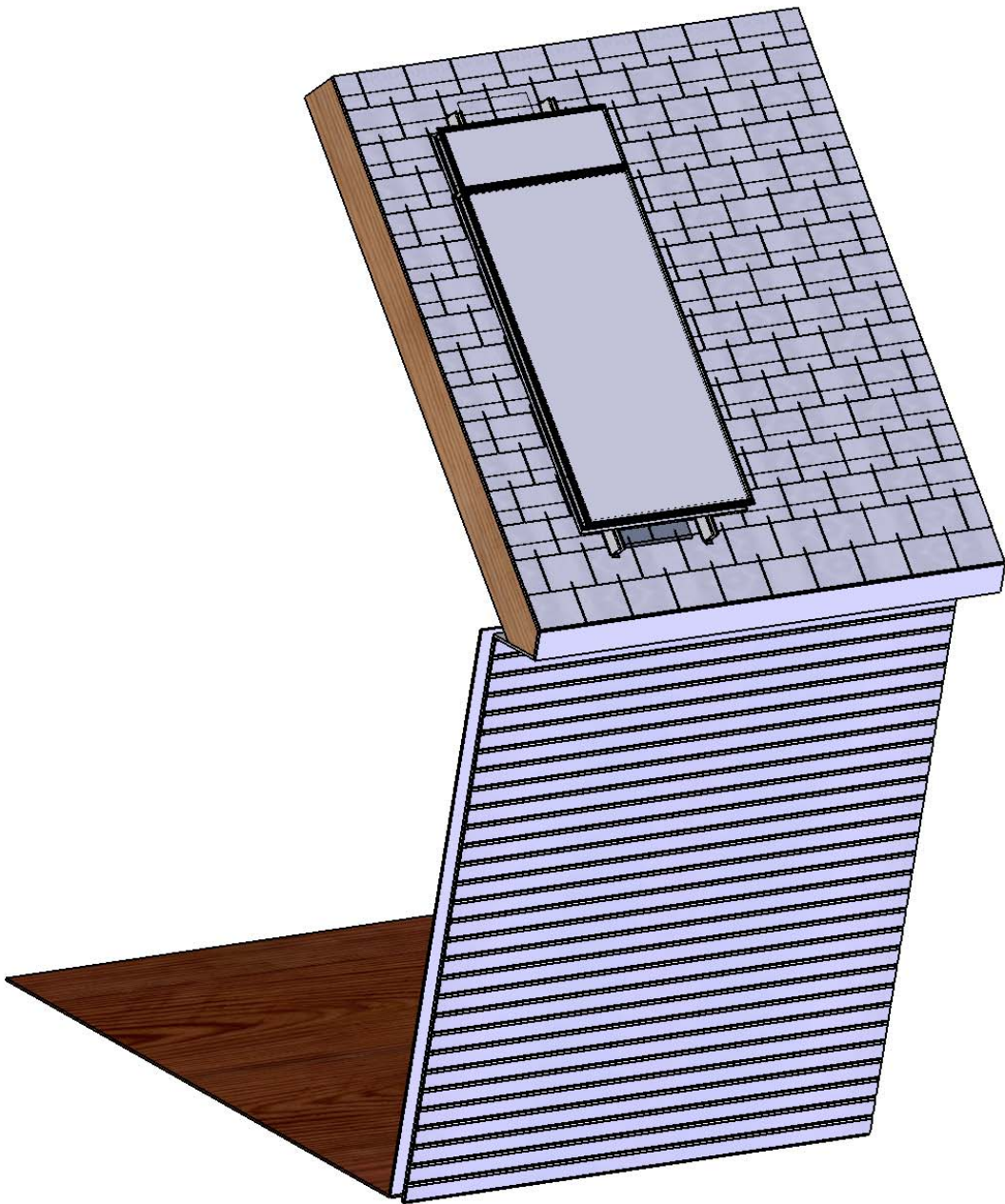

Congratulations. You have installed the SolarSheat 1500G, 1500GS, or 1501GS on your roof.